

# GLAND STYLE RUDDER PORTS | PK AND RPG SERIES

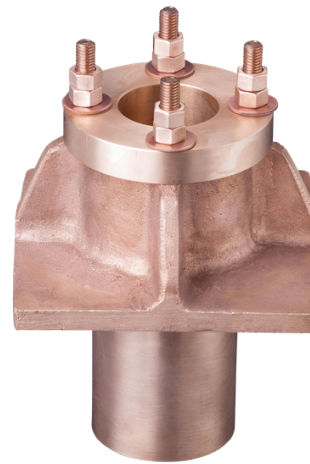
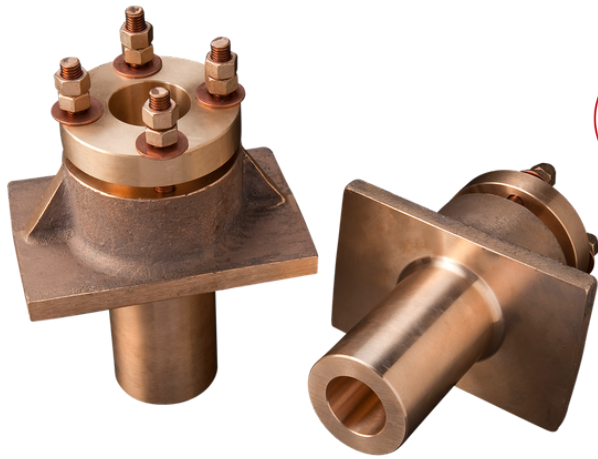

PK SERIES | GLAND STYLE

RPG SERIES | GLAND STYLE

**Heavy Duty Rudder Ports** -Traditional rudder ports require frequent adjustment of the gland nut and are prone to cracking after only a few years from fatigue. These issues can be compounded after a repowering when even more stress is exerted on the rudder's hardware. Our PK and RPG series of "gland style" rudder ports help reduce these concerns by redesigning the packing gland system and casting a more robust housing.

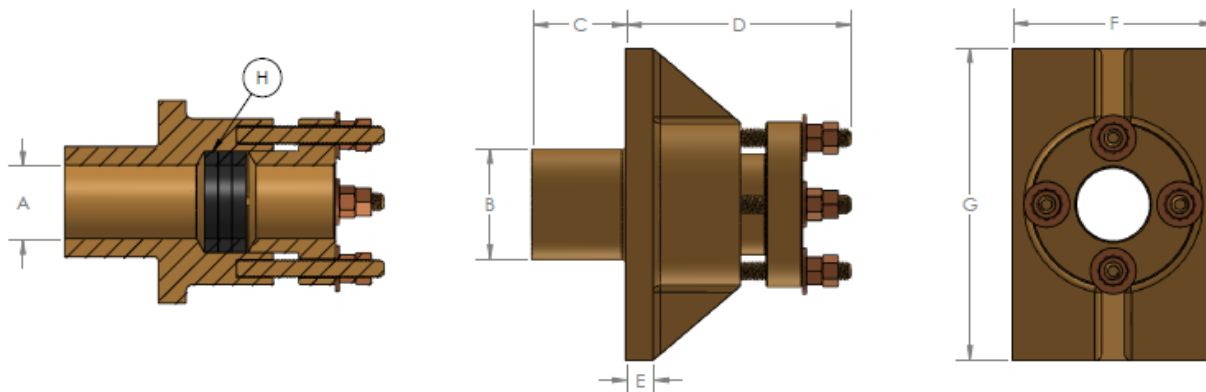

## PART SELECTOR | SIZING GUIDE

Part Number	A Shaft Diameter	B Pilot Diameter	C Pilot Length	D Exposed Length	E Flange Thickness	F Flange Width	G Flange Length	H Packing Size
PK-1500	1-1/2"	3"	2-1/2"	6"	3/4"	5-1/8"	8-1/2"	3/8"
PK-1750	1-3/4"	3"	2-1/2"	6"	3/4"	5-1/8" & 6"	8-1/2"	3/8"
PK-1750-L	1-3/4"	2-5/8" to 3"	5"	6"	3/4"	5-1/8" & 6"	8-1/2"	3/8"
PK-2000	2"	3" to 3-1/4"	2-1/2"	6"	3/4"	5-1/8" & 6"	8-1/2"	3/8"
PK-2000-L	2"	2-5/8" to 3-1/4"	5"	6"	3/4"	5-1/8" & 6"	8-1/2"	3/8"
RPG-2250	2-1/4"	3-3/4"	3-1/2" & 5"	6"	5/8"	8"	8"	3/8"
RPG-2500	2-1/2"	3-3/4"	3-1/2" & 5"	6"	5/8"	8"	8"	3/8"
RPG-3000	3"	5"	3-1/2" & 6"	6-1/4"	7/8"	10"	10"	3/8"